

P E R M I T

CITY OF NAPOLEON  
255 W. RIVERVIEW AVE  
NAPOLEON, OHIO 43545

DIVISION OF BUILDING & ZONING  
PH (419) 592-4010  
FAX (419) 599-8393

PERMIT NO: 97065

DATE ISSUED: 03-12-97

ISSUED BY: BND

JOB LOCATION: 921 SCOTT ST

EST. COST: 1500.00

LOT #:

SUBDIVISION NAME:

OWNER: NULTON, WAYNE  
ADDRESS: 921 SCOTT ST  
CSZ: NAPOLEON, OH 43545  
PHONE: 419-592-1026

AGENT: MEL LANZER CO  
ADDRESS: 2266 SCOTT ST  
CSZ: NAPOLEON, OH 43545  
PHONE: 419-592-2801

USE TYPE - RESIDENTIAL:

OTHER: COMM

ZONING INFORMATION

DIST: LOT DIM: AREA: FYRD: SYRD: RYRD:  
MAX HT: # PKG SPACES: # LOADING SP: MAX LOT COV:

BOARD OF ZONING APPEALS:

WORK TYPE - NEW: X REPLMNT: ADD'N: ALTER: REMODEL:

WORK INFORMATION

DEPTH: LGTH: WIDTH: STORIES: LIVING AREA SF:  
PAGE AREA SF: HEIGHT: BLDG VOL DEMO PERMIT:

WORK DESCRIPTION

SIGN (POST 5' X 5' TWO SIDES)

FEE DESCRIPTION	PAID DATE	FEE AMOUNT DUE
SIGN PERMIT		25.00

TOTAL FEES DUE 25.00

DATE

APPLICANT SIGNATURE

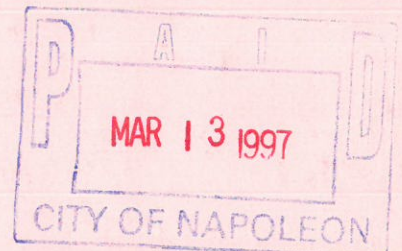



CITY OF NAPOLEON INSPECTION FORM

PERMIT #: 97065

DATE ISSUED: 03-12-97

JOB LOCATION: 921 SCOTT ST

OWNER: NULTON, WAYNE

OWNER PHONE: 419-592-1026

CONTRACTOR: MEL LANZER CO

CONTRACTOR PHONE: 419-592-2801

WORK DESCRIPTION: SIGN (POST 5' X 5' TWO SIDES)

PLUMBING:   UNDGR \_\_\_\_\_   RGHIN \_\_\_\_\_   FINAL \_\_\_\_\_

          SEWER INSP \_\_\_\_\_

MECHANICAL:   UNDGR \_\_\_\_\_   RGHIN \_\_\_\_\_   FINAL \_\_\_\_\_

          FURNACE REPLC \_\_\_\_\_   AIR COND \_\_\_\_\_

ELECTRICAL:   UNDGR \_\_\_\_\_   RGHIN \_\_\_\_\_   FINAL \_\_\_\_\_

          SERV UPGR \_\_\_\_\_

BUILDING:    SITE \_\_\_\_\_   FTG \_\_\_\_\_   FNDDT \_\_\_\_\_

          STRUC \_\_\_\_\_   ROOF \_\_\_\_\_   EXT \_\_\_\_\_

          VENT \_\_\_\_\_   ACCES \_\_\_\_\_   EGRS \_\_\_\_\_

          SMKDT \_\_\_\_\_   FINAL \_\_\_\_\_

          ISSUE TEMP OCCUP \_\_\_\_\_   ISSUE OCCUP \_\_\_\_\_

STRG SHED:   SITE \_\_\_\_\_   FINAL \_\_\_\_\_

SIGN:        FTG \_\_\_\_\_   FINAL \_\_\_\_\_

FENCE:       SITE \_\_\_\_\_   FINAL \_\_\_\_\_

MISC INSP: \_\_\_\_\_

NOTES: \_\_\_\_\_

\_\_\_\_\_

\_\_\_\_\_

INSPECTOR INITIALS: \_\_\_\_\_





**MEL LANZER CO.**  
(419) 592-2801 FAX (419) 599-2861



FAX COVER SHEET/MEMO

TO: ZONING Dept.

DATE: 3-3-97

ATTN: BRENT DAMAN

FAX NO: 599-8393

PERSON SENDING: TOM ZGELA

SUBJECT/MESSAGE: Drawings for:

Breakaway Donuts  
Sign

921 : Scott

REPLY REQUESTED: YES  NO

THIS MESSAGE HAS 3 PAGES,  
INCLUDING THIS COVER SHEET.

D  
E  
S  
I  
G  
N

C  
O  
M  
M  
E  
R  
C  
I  
A  
L

I  
N  
D  
U  
S  
T  
R  
I  
A  
L

P  
L  
A  
N  
N  
I  
N  
G

M  
I  
L  
L  
W  
O  
R  
K

R  
E  
S  
I  
D  
E  
N  
T  
I  
A  
L

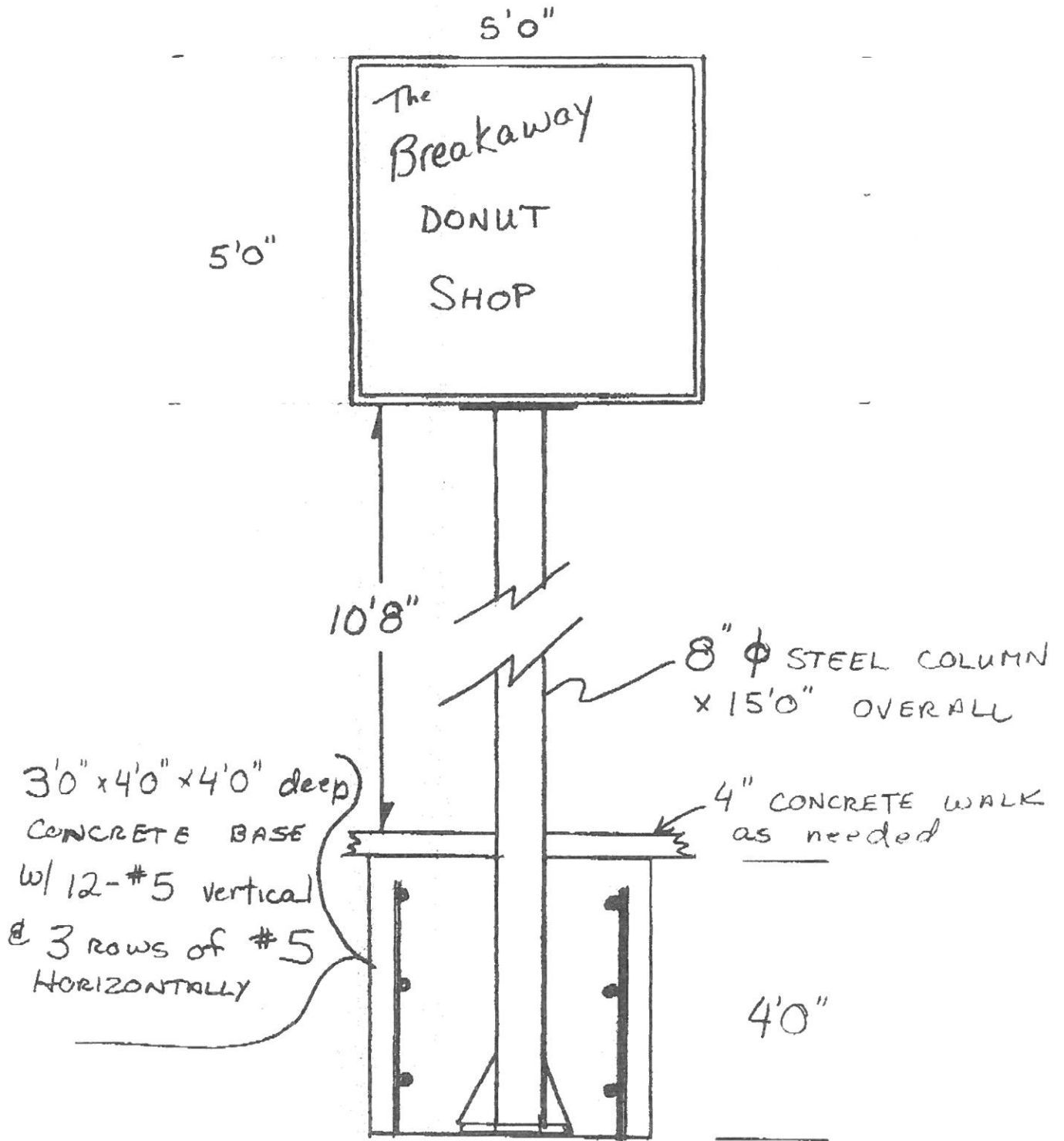

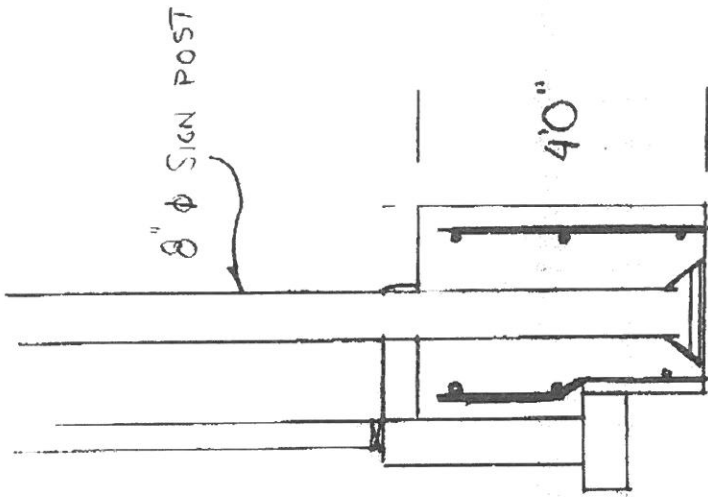
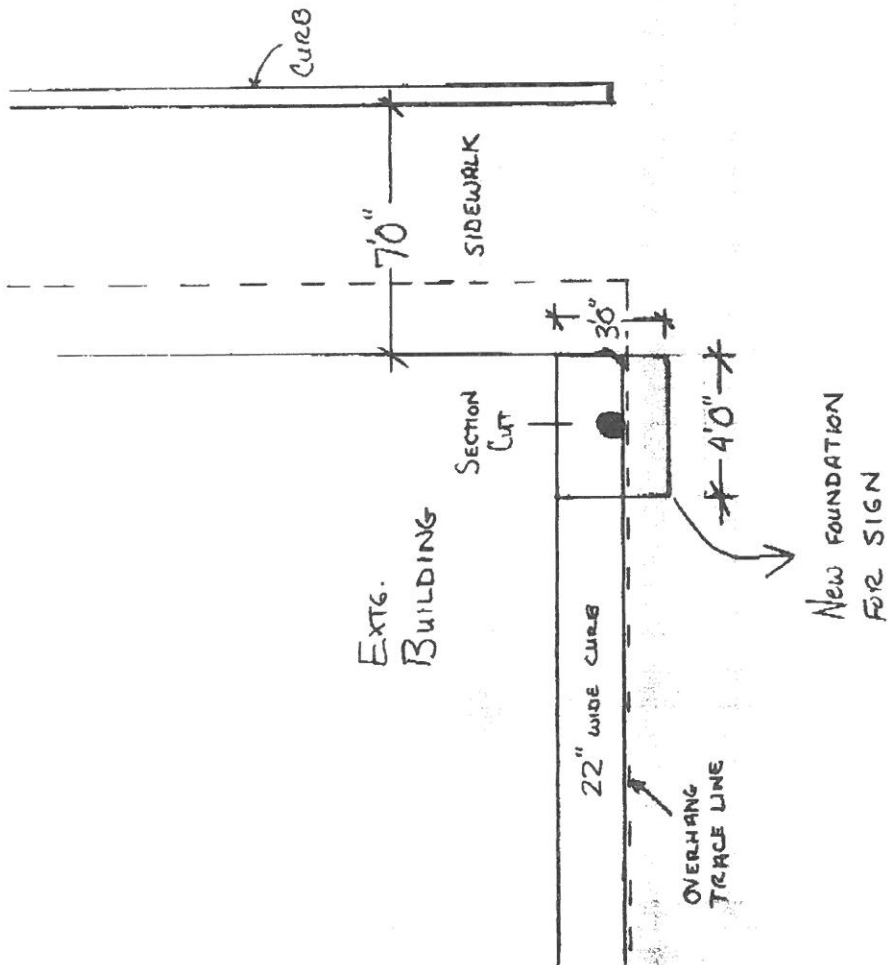

Section cut